

wk.6.torque\_work.sol

1. A student pushes on a table with a force of 20 N and pushes it in the same direction for 5.0 m. How much work does the student do?*ans:*

$$20N \cdot 5.0m = 100 \text{ joules}$$

2. If all of this work is converted to kinetic energy of the table and the table has a mass of 30 kg. how fast is the table moving?

*Comver the work done in problem one to kinetic energy*

$$100J = \frac{1}{2}mv^2$$

3. A person drags a 15 kg. block with a force of 30 N with a rope that is held at 45° above horizontal. If the the person pulls the block a horizontal distance of 2.7 m, how much work does the person do on the block?

$$30N(2.7m) \cos 45^\circ = 58J$$

4. How fast is the block moving in problem 3 after the person pulls it for 2.7 m?

*Convert the 58 J to KE just like in problem 2*

5. A person pushes a block with a force of 50 N in a direction horizontal to the floor. The block moves a distance of 10 m but its velocity does not increase. What can be said about the frictional force on the block?

- A. There is negligible friction between the block and the floor
- B. The frictional force between the block and the floor is equal to 50 N and is pointing in the same direction that the person is pushing the block.
- C. The frictional force between the block and the floor is equal to 500 joules
- D. The frictional force between the block and the floor is equal to 50 N and is pointing in the opposite direction that the person is pushing the block.

6. What is the SI unit for work?

- |           |             |           |          |              |         |
|-----------|-------------|-----------|----------|--------------|---------|
| a. meters | b. newtons  | c. joules | d. m/s   | e. $m/s^2$   | f. amps |
| g. volts  | h. coulombs | i. farads | j. watts | k. kilograms | l. ohms |

7. What is the SI unit for energy?

- |           |             |           |          |              |         |
|-----------|-------------|-----------|----------|--------------|---------|
| a. meters | b. newtons  | c. joules | d. m/s   | e. $m/s^2$   | f. amps |
| g. volts  | h. coulombs | i. farads | j. watts | k. kilograms | l. ohms |

8. What is the SI unit for force?

- |           |             |           |          |              |         |
|-----------|-------------|-----------|----------|--------------|---------|
| a. meters | b. newtons  | c. joules | d. m/s   | e. $m/s^2$   | f. amps |
| g. volts  | h. coulombs | i. farads | j. watts | k. kilograms | l. ohms |

9. A small child of mass 30 kg sits on one end of a seesaw 1.5 m from its center. A larger child of mass 47 kg. wants to sit on the opposite side of the seesaw so that his weight balances the weight of the smaller child.

(a) How much does each child weigh in proper SI units

*Multiply the mass of each child by  $9.8 m/s^2$  the second child weighs 461 N*

(b) How far from the center of the see saw should te larger child sit?

$$294N \cdot (1.5m) = 461N \cdot d$$

solve for “d”

10. You wish to lift a piano 1 meter above the ground but the piano weighs 5000 newtons. Therefore you use a ramp. You can push with a force of about 700 newtons.

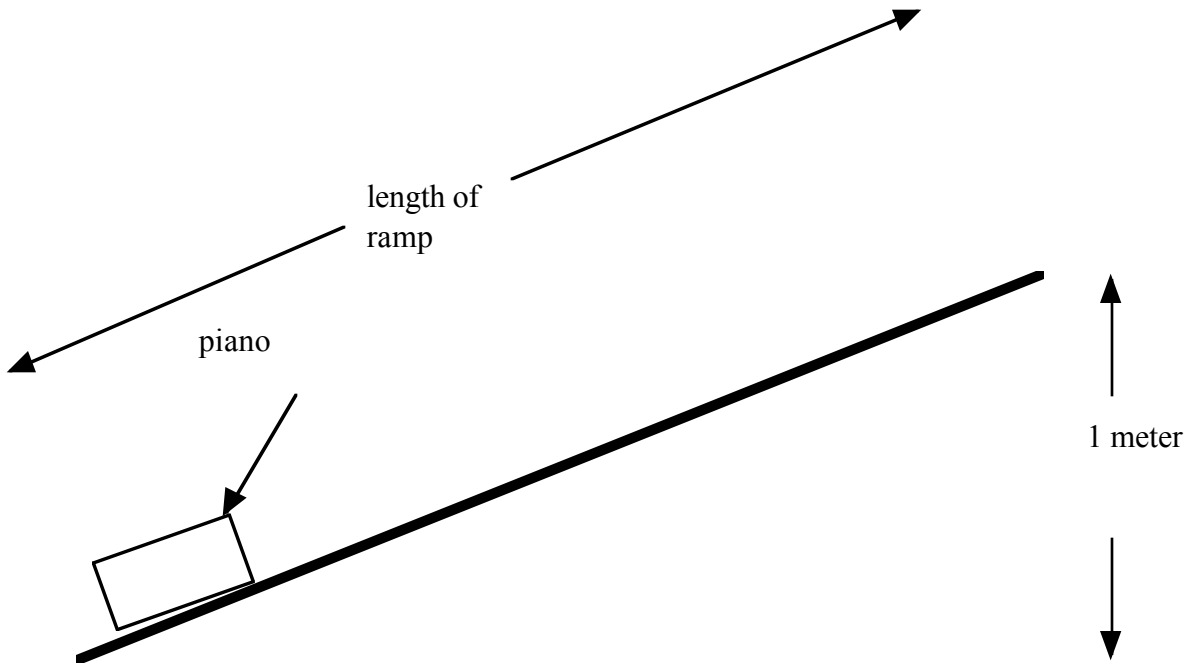

(a) If one kg = 9.8 newtons and 2.2 lbs. equals one kilogram, how much does the piano weigh in lbs. (a lb. is a measure of force, not mass). **Show conversion factors**

$$5000N \left( \frac{1kg}{9.8N} \right) \left( \frac{2.2lb}{1N} \right) = \text{_____ } lb.$$

**You must show the conversion factors like this**

(b) With what force can you push in lb.? **Show conversion factors**

(c) How much work is done in lifting the piano up one meter?

*The force is the weight of t piano (5000 N) you raise it by 1 meter. So the work is 5000J*

(d) How long does the ramp need to be for you to do this much work with the force that you can apply?

*You need to do 5000 J of work but your force is only 700 N*

*Since work equals force times distance find the distance you need to get 5000 joules of work with a force of 700 N*

(e) At what angle must the ramp be tilted to horizontal?

*The hypotenuse is the answer you got in "d" and 1 meter is the opposite side. Use trig*

11. An engineer wishes to design a sign for a restaurant. The sign hangs from a vertical beam as in the figure below.

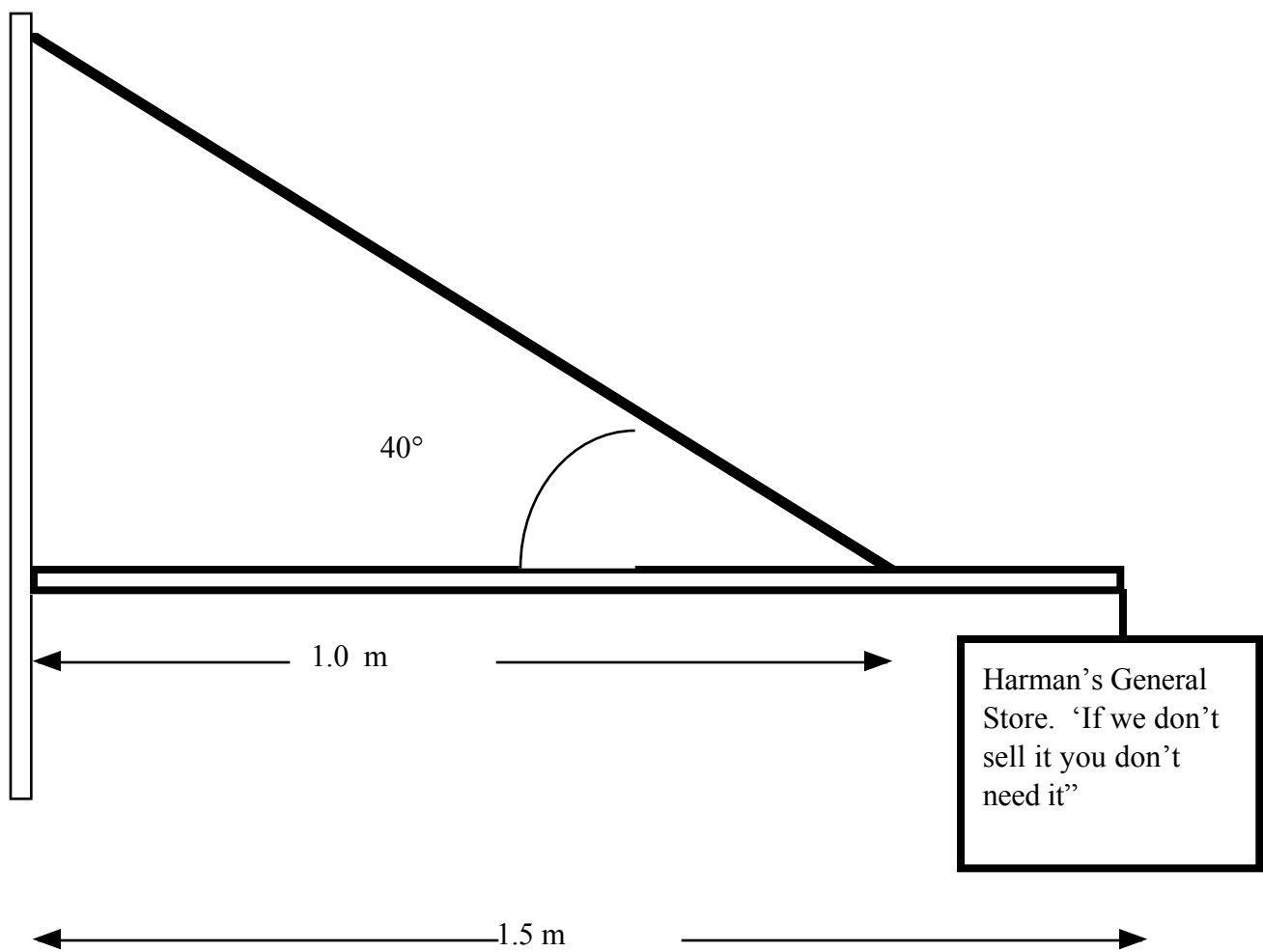

The length of the horizontal pole from which the pole hangs is 1.5 m. The pole has a weight of 500 N and the sign has a weight of 750 N. The weight of the pole acts at its center and the weight of the sign acts at the end of the pole. Both of these weights cause a torque that makes the pole rotate clockwise about the point at which the pole is attached to the wall. The engineer attaches a wire 1.0 m from the wall and extends it at a 40° angle back to the wall above the pole.

(a) Determine the torque produced by the pole itself.

*The weight of the pole acts at the midpoint of the pole (0.75 m)*

$$\text{torque} = Fd \sin\theta$$

so

$$\text{torque} = 500\text{N}(0.75\text{m})(1)$$

(b) determine the torque produced by the sign. **Do not put this answer in scientific notation, keep it to four sig figs.**

$$\text{Torque} = 750\text{N}(1.5\text{m})(1)$$

(c) Determine the total torque produced by the pole and the sign.

*JUST ADD THE TWO TORQUES YOU JUST FOUND*

(d) What must the tension in the wire be in order to offset the torque from the sign and the pole?

$$1125 \text{ Nm} = \text{Tension}(1.0\text{m})\sin(40) \quad \text{Solve for Tension be sure your calculator is set to degrees}$$

1. 100 J      2) 2.6 m/s      3) 58 J      4) 2.8 m/s
5. D    6. c joules    7. c joules      8. b newtons
9. (a) 294 newtons    (b) 0.96 m      10. (a)  $11.1 \times 10^3$  lbs
- (b) 157 lb.    (c) 5000 J      (d) 7.1 m    (e) 8.2° (arcsine of 1/7.1)
- 11.(a) 375 N•m    (b) 1125 N•m    (c) 1500 N•m      (d)  $2.3 \times 10^3$  N